

### Counter for all types of juices

*Can be used in a pumping line*

Light and mobile meter

Determine the pumping time and volume to be transferred

#### TECHNICAL FEATURES:

- Stainless steel frame
- Air vent valve for filling perfectly the piping
- Easy cleaning and total emptying (none liquid retention in the piping)
- Control of all compatible pumps (servo control)



#### OPTION

- Motorized butterfly valve

#### ELECTRICAL CONNECTIONS

- 10 metres of electric cable with standard jack

### LCD display as standard



- Easy adjustment
- Viewing transfer parameters
- Comfort of use

### Remote control as standard



- On/off
- Induction rechargeable
- Very long range
- Digital display with charge indicator
- Unique coding to avoid interference

## ÆNOFLUX® | DIMENSIONED DRAWING

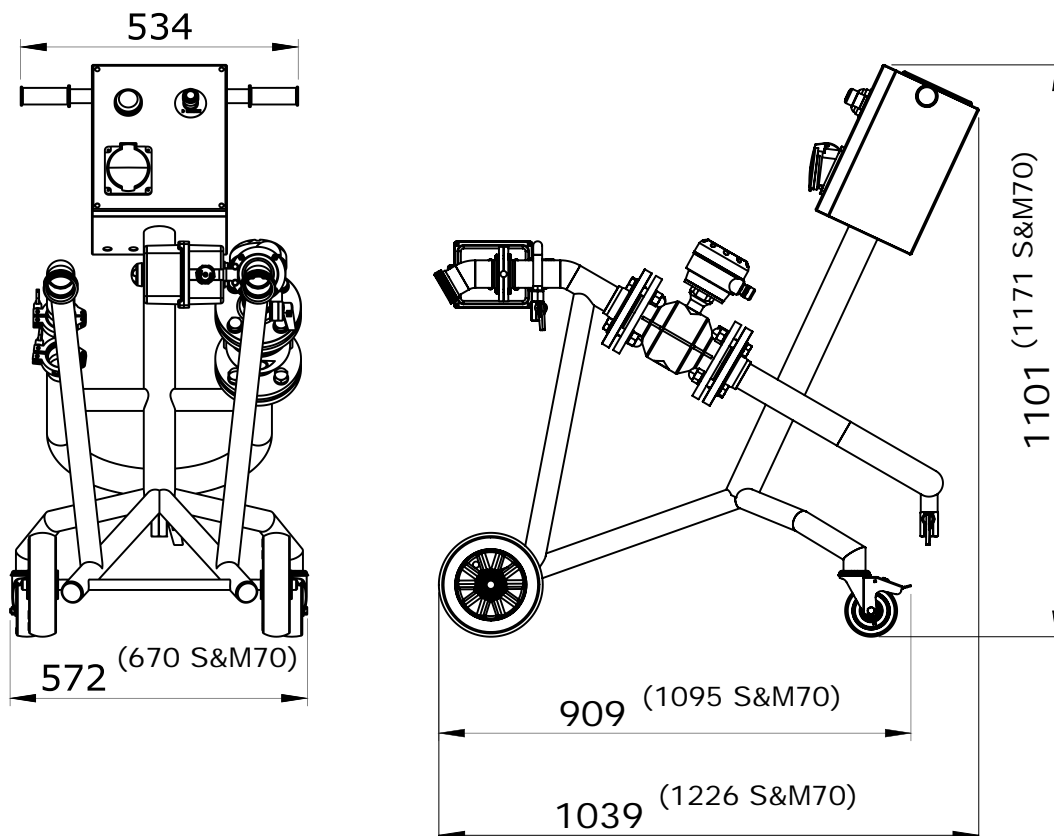

Non-contractual photos - In order to ensure quality, PMH Vinicole reserves the right to improve the technical specifications of its products at any time and without notice. 11/2018

ZA - 41 allée de la Croix des Hormes - 69250 Montanay - FRANCE  
 Tel. +33 (0)4 72 21 83 00 - Fax +33 (0)4 72 51 43 17  
 info@pmh-vinicole.fr

# PMHVINICOLE

TRADITIONAL MATERIALS & INNOVATIVE SOLUTIONS

[www.pmh-vinicole.fr](http://www.pmh-vinicole.fr)